

# GSH-630 Fryderyk

DIRECT DRIVE TURNTABLE

User Manual

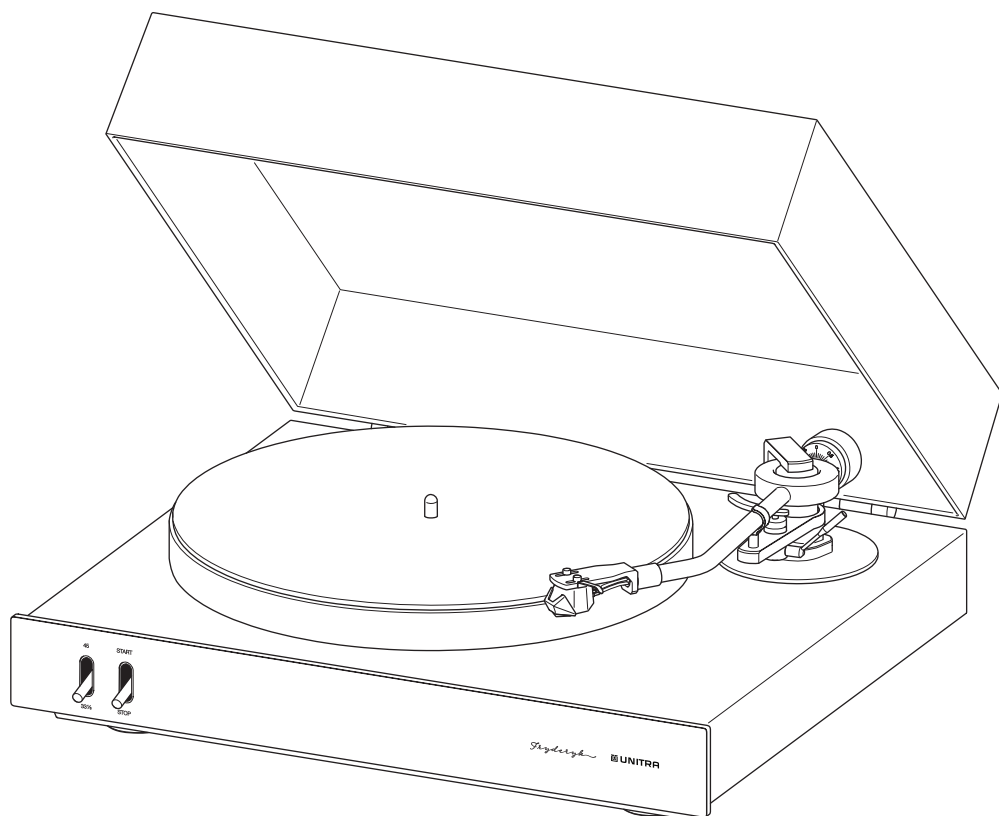

# Contents

<b>Manufacturer</b> .....	<b>3</b>
<b>About this document</b> .....	<b>4</b>
Symbols used in this manual .....	4
Safety .....	4
Acronyms, abbreviations, and technical terms .....	5
<b>Description</b> .....	<b>5</b>
Content of the package .....	5
Overview .....	6
Recommendations for use .....	9
<b>Assembly</b> .....	<b>10</b>
Assembly of the platter .....	10
Removing the headshell .....	10
Attaching the cartridge .....	11
Aligning the cartridge .....	12
Attaching the tonearm counterweight .....	13
Setting the stylus pressure .....	14
Adjusting the anti-skating force .....	15
Adjusting the vertical tracking angle (VTA) .....	16
Adjusting the azimuth .....	17
Adjusting the dust cover .....	18
<b>Connections</b> .....	<b>19</b>
Connecting to a preamplifier or amplifier .....	19
Connecting the AC power cable .....	20
<b>Operation</b> .....	<b>21</b>
Playing a record .....	21
When the record ends .....	21
<b>Maintenance</b> .....	<b>22</b>
Maintenance of the stylus .....	22
Cleaning of the plinth .....	22
Cleaning of the dust cover .....	22
<b>Troubleshooting</b> .....	<b>23</b>
<b>Technical specifications</b> .....	<b>24</b>
<b>Dimensions</b> .....	<b>25</b>
<b>Disposal</b> .....	<b>26</b>

# Manufacturer



Unitra sp. z o.o.  
 Przejazdowa 2b,  
 02-496 Warsaw, Poland  
 website: [www.unitra.com](http://www.unitra.com)

## About this document

Thank you for purchasing this Unitra product.

To ensure proper operation, read this manual carefully and operate the device in accordance with the instructions contained in it. Please keep this manual for future reference after reading it.

## Symbols used in this manual

	<b>WARNING</b>	Describes precautions to be followed to avoid the possibility of serious injury or even death.
	<b>CAUTION</b>	Describes precautions to be followed to avoid injury.
	<b>NOTICE</b>	Describes precautions to be followed to avoid malfunction or damage to the product.
	<b>NOTE</b>	Describes supplemental information about the product.

## Safety

	<b>WARNING</b> Carefully read the Safety Brochure before use and keep it for future reference.
--	---

## Acronyms, abbreviations, and technical terms

GND	Grounding
RCA	Connector type introduced by the Radio Corporation of America
RPM	Revolutions per minute, a record speed unit
VTA	Vertical Tracking Angle

## Description

### Content of the package

Make sure that the following elements are included in the package:

- Device (GSH-630 Fryderyk Direct Drive Turntable)
- Platter
- Felt mat
- Phono cartridge
- Anti-skating weight with string
- Counterweight
- Phono cable (double RCA with grounding wire)
- Power cord
- Cartridge Alignment Protractor
- User Manual (this book)
- Safety Brochure
- Warranty Card

## Overview

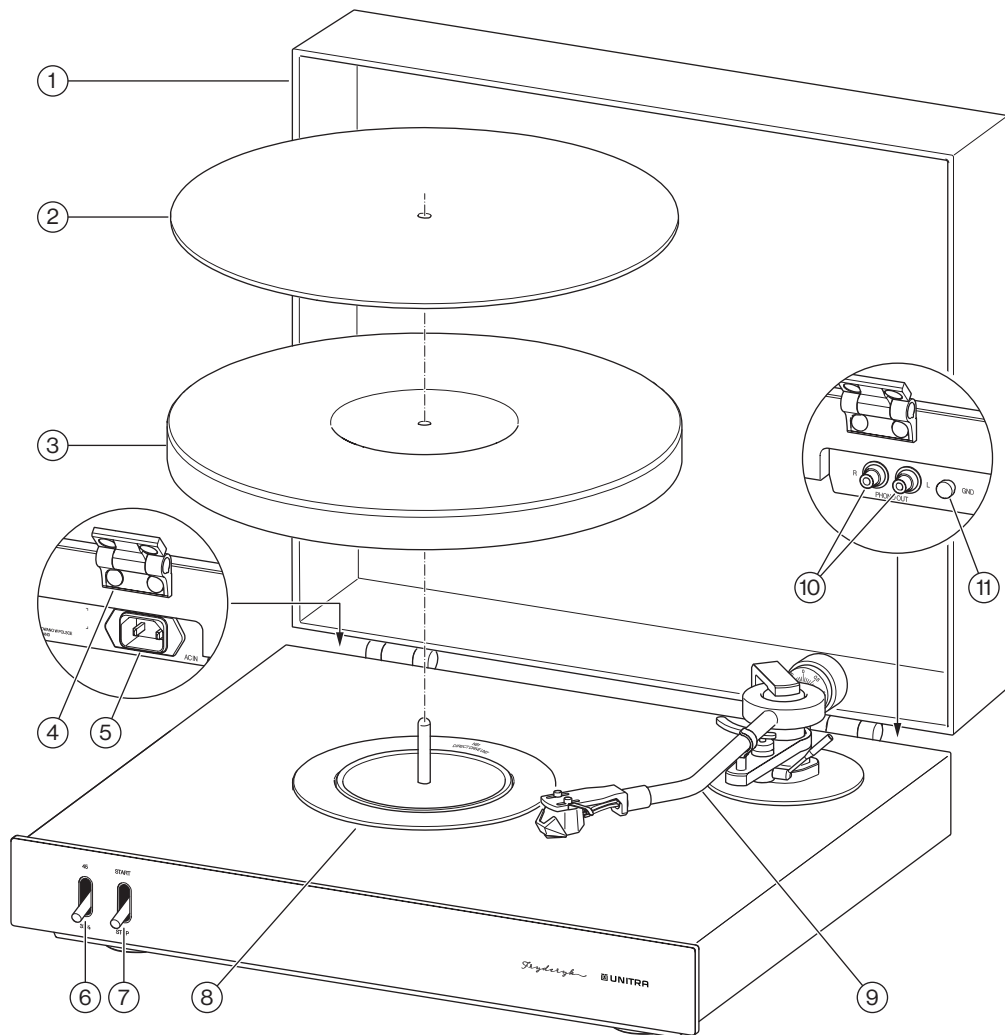

- ① **Dust cover**
- ② **Felt mat**
- ③ **Platter**
- ④ **Dust cover hinge**
- ⑤ **AC inlet**
- ⑥ **Speed selection switch**

Switch up	45	To play records with the speed of 45 RPM.
Switch down	33½	To play records with the speed of 33½ RPM.

⑦ **START/STOP switch**

Switch up	START	The platter turns.
Switch down	STOP	The platter does not turn.

- ⑧ **Direct drive**
- ⑨ **Tonearm**
- ⑩ **PHONO OUT jacks**
- ⑪ **GND terminal**

**Tonearm**

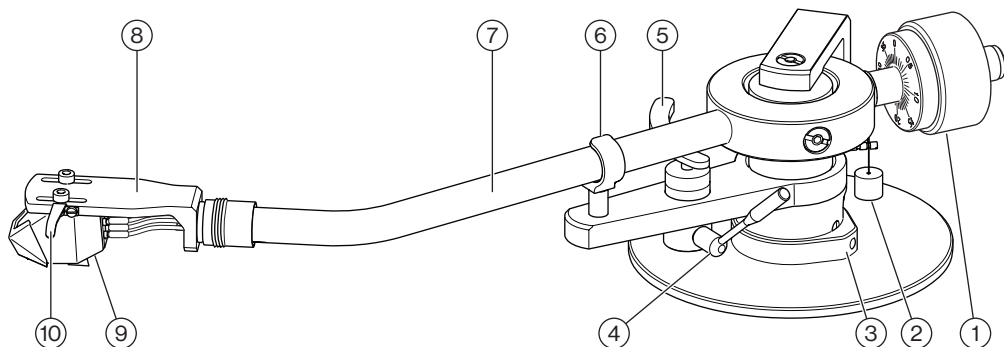

- ① Counterweight
- ② Anti-skating weight
- ③ Tonearm height adjustment flange
- ④ Tonearm lift lever
- ⑤ Tonearm lift
- ⑥ Tonearm rest
- ⑦ Tonearm tube
- ⑧ Headshell
- ⑨ Phono cartridge
- ⑩ Finger lift

## Recommendations for use

**NOTICE**

**If you plan not to use the Device for a long period of time, make sure that the Device is disconnected from the AC power source.**

**NOTICE**

**Do not stop the spinning platter with your hand.**

- When frequent transient states and impulse distractions in the power line happen, distractions on output connectors may occur. Those interferences may impact audio signal amplification quality and can generate sound distortions. When distractions on the power line end, the device returns to normal operation.
- Place the Device in a distance from heat sources (e. g. room heaters).
- Place the Device on a flat and even surface.
- For transport, remove the platter and secure the tonearm to the tonearm rest (e.g. with a wire).



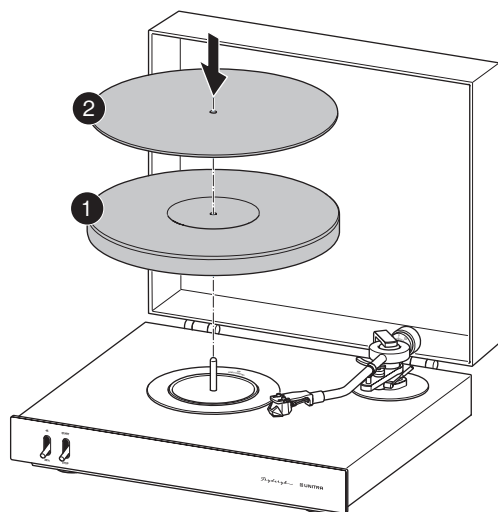

## Assembly

### Assembly of the platter

#### Step 1

Put the platter on the spindle. Make sure that the correct side of the platter is facing upwards.

#### Step 2

Put the felt mat on the platter.

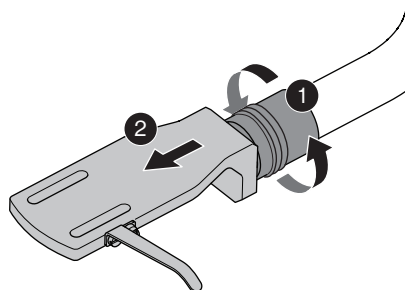

### Removing the headshell

#### Step 1

Loosen the nut that secures the headshell until the headshell is released.

#### Step 2

Carefully remove the headshell from the tonearm. Make sure that you do not twist or bend the headshell or put excessive force on the tonearm.

## Attaching the cartridge

For your convenience, you can remove the headshell from the tonearm to attach the cartridge.  p. 10.

You can use all types of cartridges with a half-inch mount.

**Tools:** set of hex keys (if a key is not supplied with the cartridge)

### Step 1

Remove the cartridge from the package and follow the included instructions.

Make sure that the cover is on the cartridge so that the stylus is protected.

### Step 2

Connect the tonearm wires with the cartridge pins according to the color codes:

white	Left channel positive (L+)
-------	----------------------------

blue	Left channel return (L-)
------	--------------------------

red	Right channel positive (R+)
-----	-----------------------------

green	Right channel return (R-)
-------	---------------------------

The tonearm comes with the wires connected to the tonearm pins. In case it is necessary, connect the wires according to the color codes above and the channel markings shown in the illustration.

### Step 3

Fit the cartridge to the headshell and secure it with the screws supplied with the cartridge. Do not tighten the screws yet.

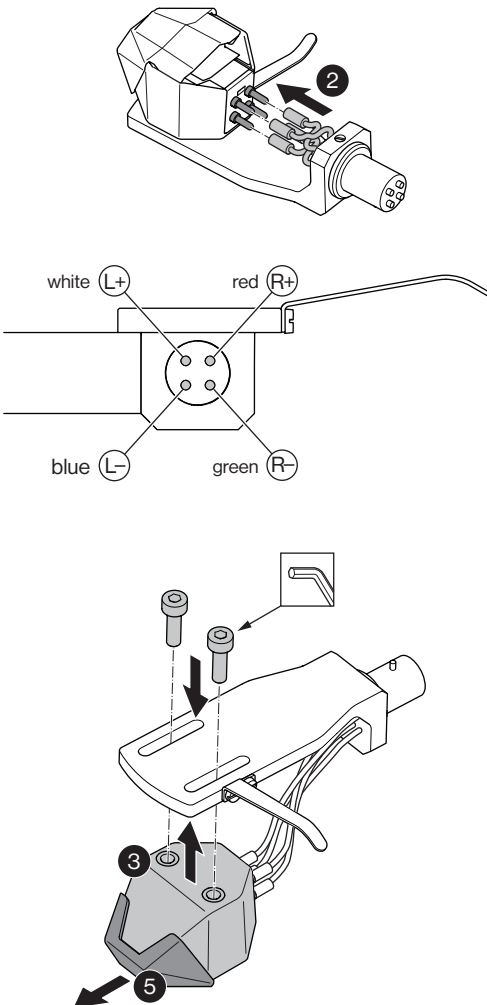

## Aligning the cartridge

**Tools:** set of hex keys (if a key is not supplied with the cartridge), and cartridge alignment protractor.

### NOTE

You can use other tools that support precise cartridge alignment. For more info and instructions visit [www.unitra.com](http://www.unitra.com).

### Step 1

Place the cartridge alignment protractor on the platter. Make sure it lies flat and is secured in place.

### Step 2

Remove the cover from the stylus and carefully position the stylus on the protractor's alignment grid so that it points one of the circles.

### Step 3

Align the cartridge with the grid lines on both grids, so that the stylus points directly to both the circles.

### Step 4

Make sure that the cartridge is in the correct position. It must be parallel with the grid on the protractor.

### Step 5

Tighten the screws. Be careful that the cartridge does not move out of place. Proper cartridge alignment minimizes tracking error and distortion, optimizing sound quality during playback.

## Attaching the tonearm counterweight

The tonearm counterweight has two parts that are connected magnetically. If these parts are apart, put them together before attaching the counterweight on the tonearm.

### Step 1

Put the tonearm counterweight on the rear of the tonearm.

### Step 2

Turn the tonearm counterweight to move it closer to the center of the tonearm.

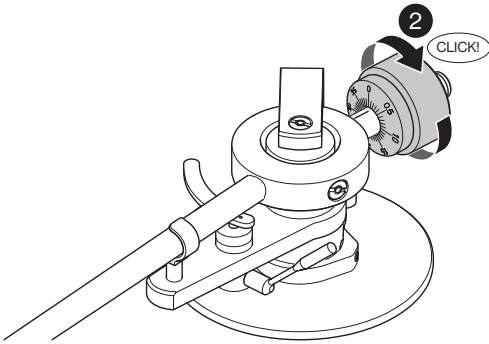
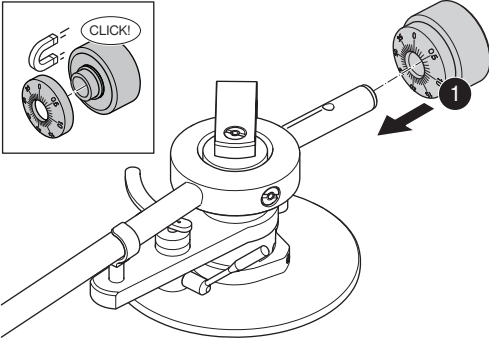

## Setting the stylus pressure

### NOTICE

The cover must be removed from the cartridge to adjust the tonearm balance correctly. Be careful not to damage the stylus. Prevent the stylus from touching the platter or the plinth.

### NOTE

Alternatively to presented stylus pressure setting technique you can use a weight scale. For more info and instructions visit [www.unitra.com](http://www.unitra.com).

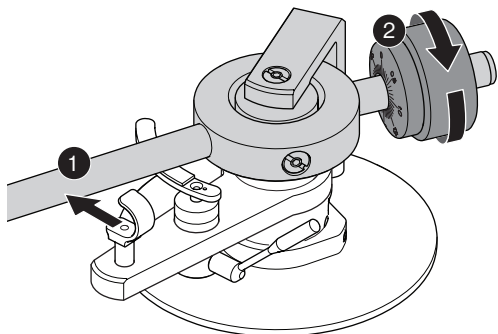

### Step 1

Remove the tonearm from the tonearm rest.

### Step 2

Hold the tonearm and turn the counterweight to adjust the balance until the tonearm is balanced. The stylus pressure is "0".

### Step 3

Turn the smaller part of the counterweight until the "0" on the scale comes to the centre line of the rear of the tonearm. Make sure the other part of the counterweight stays in place.

### Step 4

Turn the counterweight to adjust the stylus pressure appropriate for the installed cartridge:

- Both parts turn together.
- Turn until the centre line points to the appropriate stylus pressure. The scale reflects the stylus pressure in grams.

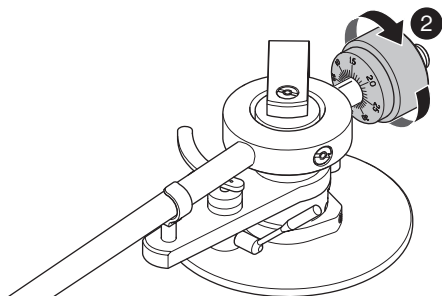
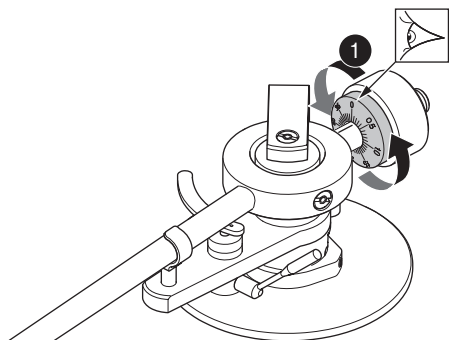
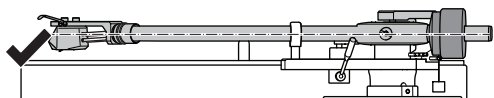

## Adjusting the anti-skating force

### NOTE

The anti-skating force depends on the type of cartridge in use and the set stylus pressure.

### Step 1

Put the anti-skating string hook on the anti-skating pin with three grooves.

### Step 2

Put the string with the anti-skating weight in the groove of the second anti-skating pin, so that the weight hangs freely.

### Step 3

Adjust the anti-skating force by putting the anti-skating string hook in the appropriate groove as follows:

Stylus pressure	Groove on the anti-skating pin
0 – 1.4 g	Groove A
1.5 – 2 g	Groove B
≥ 2 g	Groove C

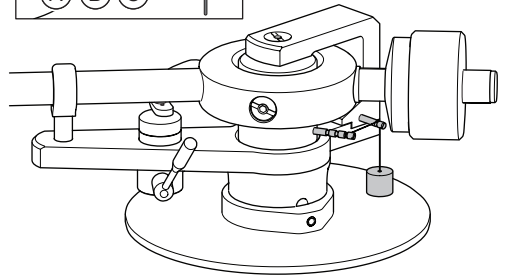
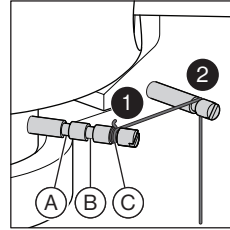

## Adjusting the vertical tracking angle (VTA)

To check if the VTA is set correctly put a record on the platter. When the needle is lowered into the record groove and the tonearm is not resting on the tonearm lift, the tonearm should be parallel to the surface of the record.

**Tools:** set of hex keys (not included)

### Step 1

Hold the tonearm to secure it and carefully loosen the screw on the tonearm adjustment flange. Do not loosen the screw excessively.

### Step 2

Adjust the height of the tonearm to set the correct VTA.

### Step 3

Hold the tonearm in the correct position and tighten the screw on the tonearm adjustment flange.

Make sure that the screw is in the correct position in the rotation blocking groove: you cannot rotate the arm.

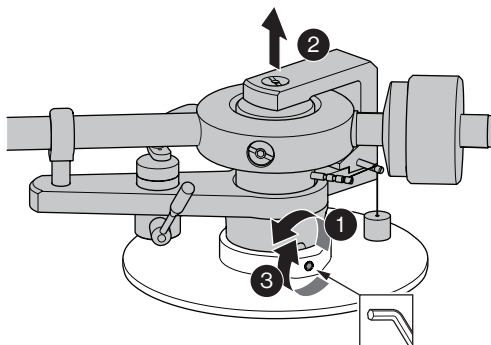

## Adjusting the azimuth

The stylus must be vertical in the record groove. The Device comes with a pre-set azimuth, but after replacement of the cartridge it is possible that adjustment of the azimuth is necessary.

**Tools:** set of hex keys (not included)

### Step 1

Loosen the screw on the rear side of the headshell. Do not remove the screw completely.

### Step 2

Adjust the azimuth, so that the surface of the headshell is parallel to the platter.

### Step 3

Tighten the screw on the rear side of the headshell.

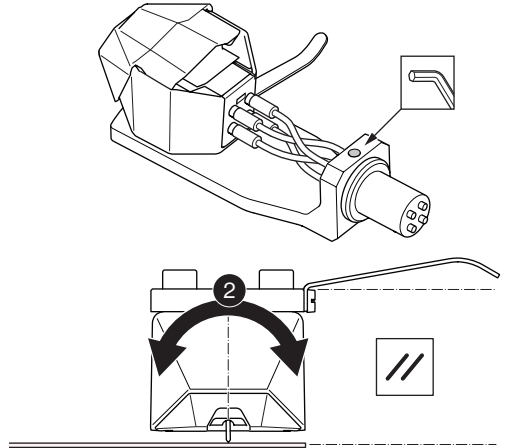



## Adjusting the dust cover

You can adjust the friction level of the dust cover hinges or remove the dust cover entirely.

### Adjusting the friction

**NOTE**

If the friction is too low, the dust cover can move uncontrollably and there is a risk of damage to the cover.

**Tools:** set of hex keys (not included)

Tighten or loosen the screws on the sides of the hinges.

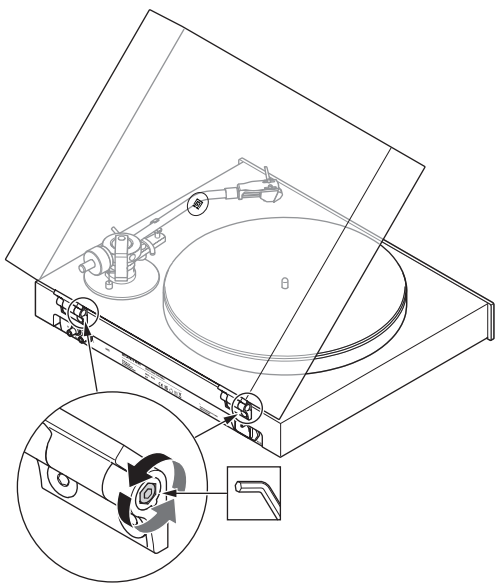

### Removing the dust cover

**Tools:** set of hex keys (not included)

Loosen the bottom pair of screws on both hinges and remove the dust cover.  
Store the screws together with the dust cover.

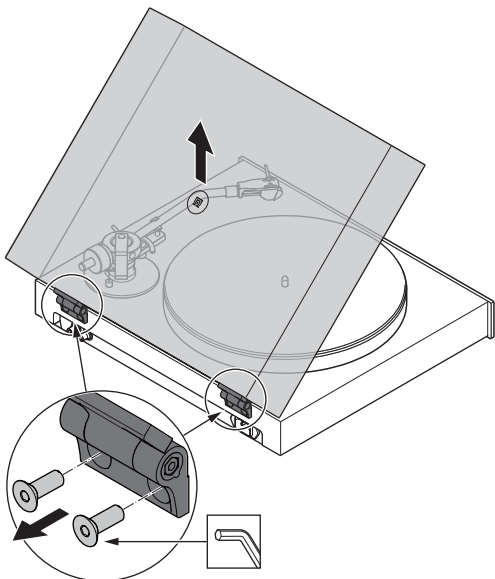

# Connections

## Connecting to a preamplifier or amplifier

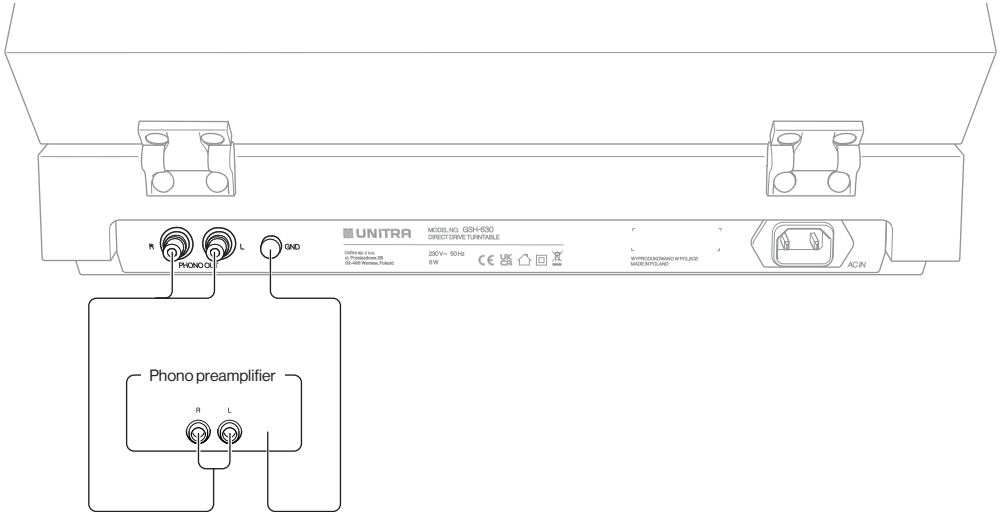

### CAUTION

Connect the Device to the preamplifier or amplifier before you connect the Device to the AC power source.  p. 20.

You can connect the Device to the preamplifier or amplifier, if it has an integrated preamplifier block. Use the supplied RCA phono cable with grounding wire.

## Connecting the AC power cable



### CAUTION

Install the Device in accordance with the Safety Brochure (section Installation) enclosed to this product.

After all connections are ready, you can connect the Device to the AC power source.

### Step 1

Connect the power cord to the AC inlet.

### Step 2

Connect the power cord to the AC power source.

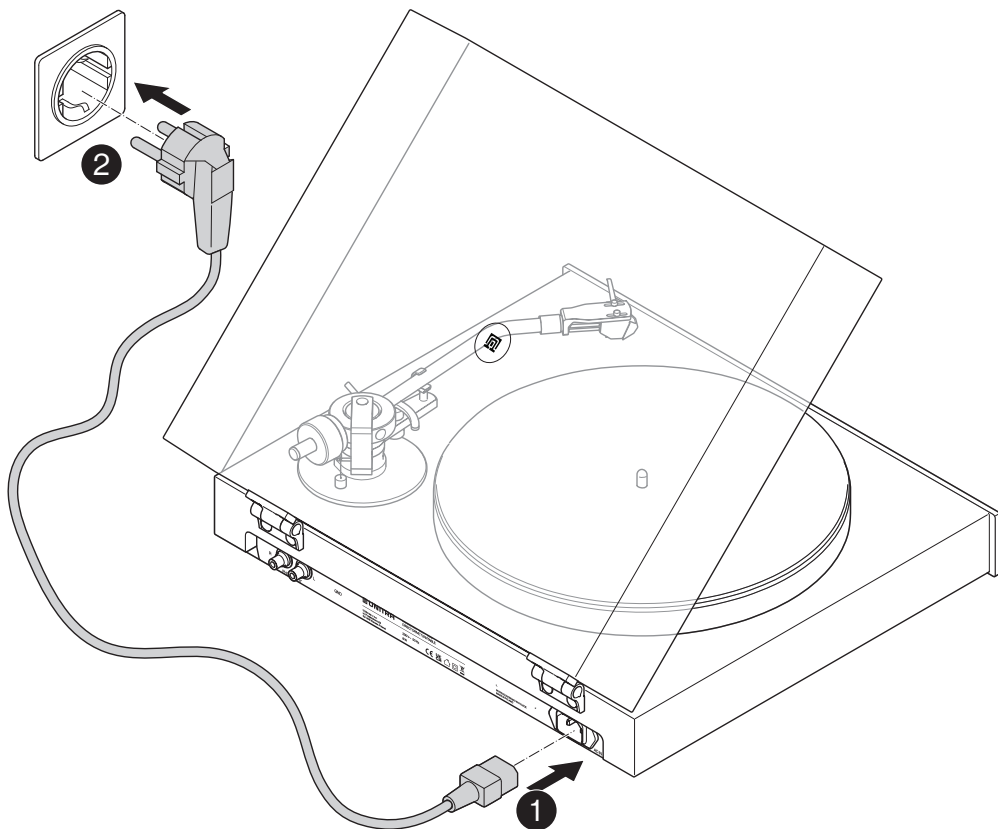

# Operation

## Playing a record

### Step 1

Put the record on the platter.

### Step 2

Set the speed on the Speed control switch according to the record speed.

### Step 3

Remove the cover from the cartridge (if used).

### Step 4

Make sure that the tonearm lift lever is in up position.

### Step 5

Set the START/STOP switch to the "START" position to start the turntable.

### Step 6

Move the tonearm over the record with the finger lift to the selected track position.

### Step 7

Lower the tonearm lift lever.

## When the record ends

### Step 1

Lift the tonearm lift lever up and return the tonearm to the tonearm rest.

### Step 2

Set the START/STOP switch on the "STOP" position.

### Step 3

Put the cover back on the cartridge.

## Maintenance

### Maintenance of the stylus

Refer to the instructions of the cartridge manufacturer.

### Cleaning of the plinth

The plinth is made of varnished wood veneer. For occasional cleaning use a soft, slightly dampened cloth.

Do not use any cleaner or wax.

**NOTICE**

**Be careful not to damage the stylus tip. Put the cover on the cartridge before cleaning.**

### Cleaning of the dust cover

Use a soft, slightly dampened cloth.

Do not use any solvents (e.g. benzene, alcohol, chemical wipers).

# Troubleshooting

Most difficulties in audio systems are the result of incorrect connections, or improper control settings. If you encounter problems, localise the area of the difficulty, check the control settings, determine the cause of the fault and make the necessary changes. If you are unable to get a correct sound from the Device, refer to the suggestions for the following conditions:

<b>Problem</b>	<b>Cause</b>	<b>Remedy</b>
The turntable does not start.	The power cable is not connected to the AC inlet on the rear panel or is not connected to an AC power source.	Make sure that the power cord is properly connected to the power source. After that, disconnect the power cord from the power source, wait for at least 5 seconds and connect the power cord again.
	A hardware error occurred.	Disconnect the Device from the AC power source, wait for at least 30 seconds and connect the Device again.  p. 20.
The platter is turning but there is no sound.	The Device is connected to the wrong input terminal on the preamplifier or amplifier.	Make sure that you connected the turntable to the PHONO jacks on the preamplifier or amplifier.
	The cables are not connected properly.	Make sure that the cables from the Device to the pre-amplifier or amplifier input jacks are connected properly. Make sure that the speaker cables are connected with the correct polarity and that they are pushed into the terminal all the way.
	The input source is not correctly selected on the preamplifier or amplifier.	Make sure that the correct input source is selected on the preamplifier or amplifier.
The sound is distorted or too low.	The cables to the pre-amplifier or amplifier are not connected properly.	Make sure that the cables from the Device to the pre-amplifier or amplifier input jacks are connected properly.
	The cartridge type (MM/MC) is not correctly set on the pre-amplifier or amplifier.	Make sure that the cartridge type (MM/MC) is set according to the type that is used in the Device. Refer to the manual of your pre-amplifier or amplifier.
	The ground wire is not connected.	Check if the ground wire is connected to the GND terminals on the Device and the pre-amplifier or amplifier.

## Technical specifications

### Tonearm

Model	Unitra R10
Material	Aluminum
Bearings	Two pairs of bearings on cone pins
Effective length	228.22 mm
VTA adjustment	Yes
Supported cartridge weight range	3 – 12 g

### Drive

Model	Unitra NB1
Drive method	Direct drive
Motor type	Axial flux
Rotation control	Digital controller
Nominal speeds	33⅓ RPM, 45 RPM
Wow & Flutter	

### General

Dimensions with closed dust cover (Width × Depth × Height)	440 × 471.3 × 151.9 mm
Mass	11.7 kg
Platter material	HDPE
Platter mass	1.6 kg
Power supply type	Internal
Power supply	230 V AC, 50 Hz, 6 W
Max. power consumption	6 W
Power consumption (standby)	<0.5 W
Insulation category	Class II
Indoor/outdoor use	Indoor use only
Compliance	CE, UKCA, IEC 62368-1

# Dimensions

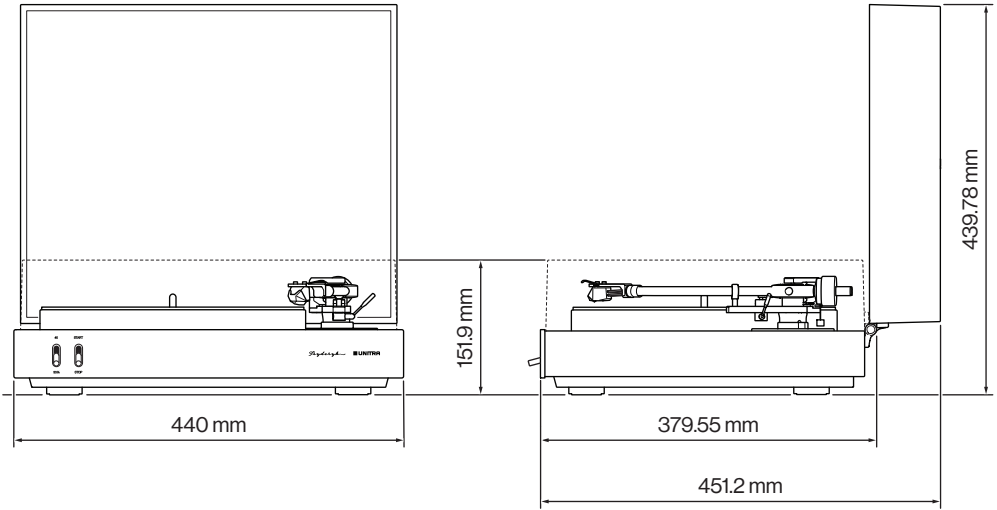



## Disposal

This Device is labeled in accordance with the European Directive 2002/96/EC concerning waste electrical and electronic equipment (WEEE).

The Device or used and fully discharged batteries should not be disposed of with household waste. Since the transposition of Directive 2002/96/EC into the national law electric and electronic equipment must not be disposed of together with household waste and the user is obliged to dispose of a broken or redundant electrical or electronic device at a dedicated collection point, put it in a special container, or possibly return it to the seller. When disposing of the device and batteries, comply with applicable local regulations. To ensure proper disposal of the device, contact a special disposal and recycling facility for electrical and electronic equipment. The address can be obtained from your environmental officer or city council.



The details are set forth in the relevant national laws. This obligation is indicated on the product packaging or in the manual in the form of a crossed-out waste bin. By sorting waste for recycling, you help to protect the natural environment.



Copyright: Unitra sp. z o.o.  
Revision 2 (2024-01-12)

For more information go to:  
<https://www.unitra.com/>  
or scan QR code below.

